

Hammond

Flat Finishers

Single or Multiple Heads

- Sizing
- Fine Finishing
- Deburring
- Polishing
- Grinding
- Brushing

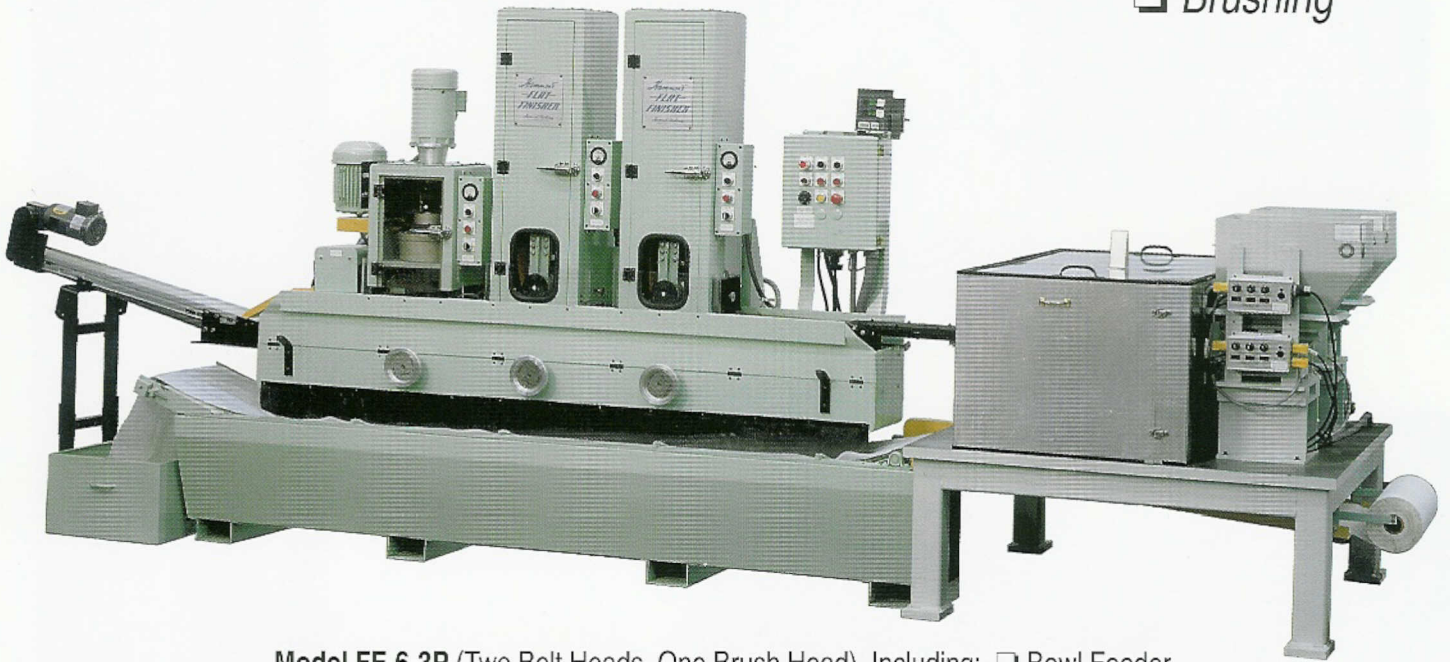

Model FF-6-3P (Two Belt Heads, One Brush Head) Including: Bowl Feeder
 Unload Conveyor Power Head Elevation With Digital Readout Coolant System With Filter

Rough

Step 1

Step 2

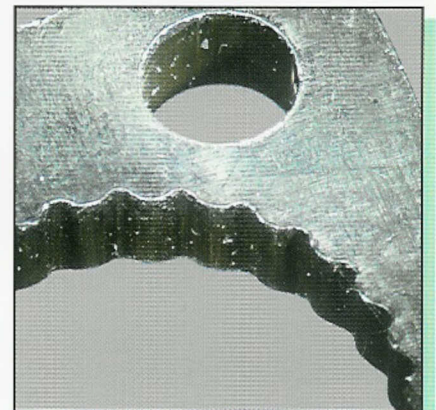
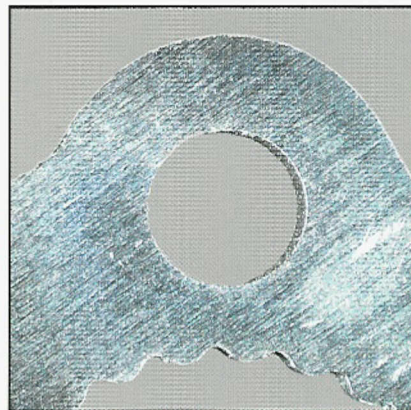
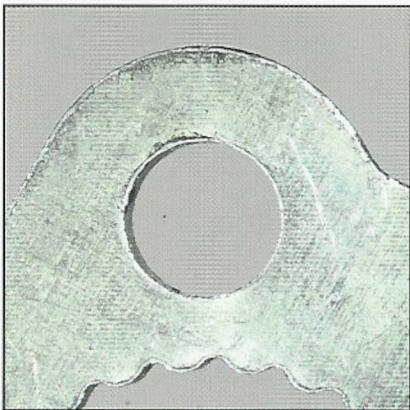

After Fineblank

Abrasive Belt
Deburr and Size
Within .003"

Edge Break
With Planetary Head
2000/Hr.

Planetary Brush Head

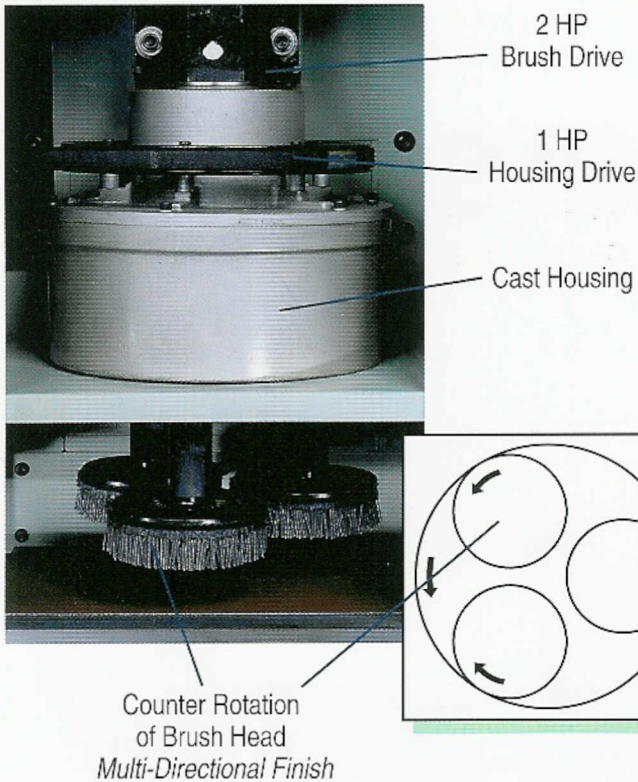

Abrasive Belt Head

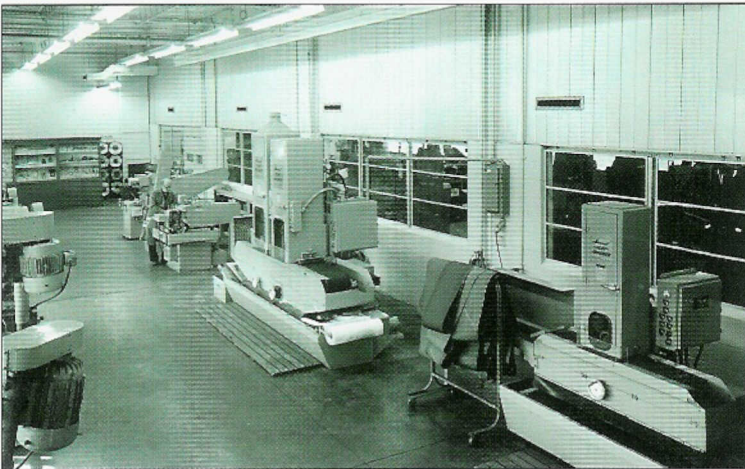
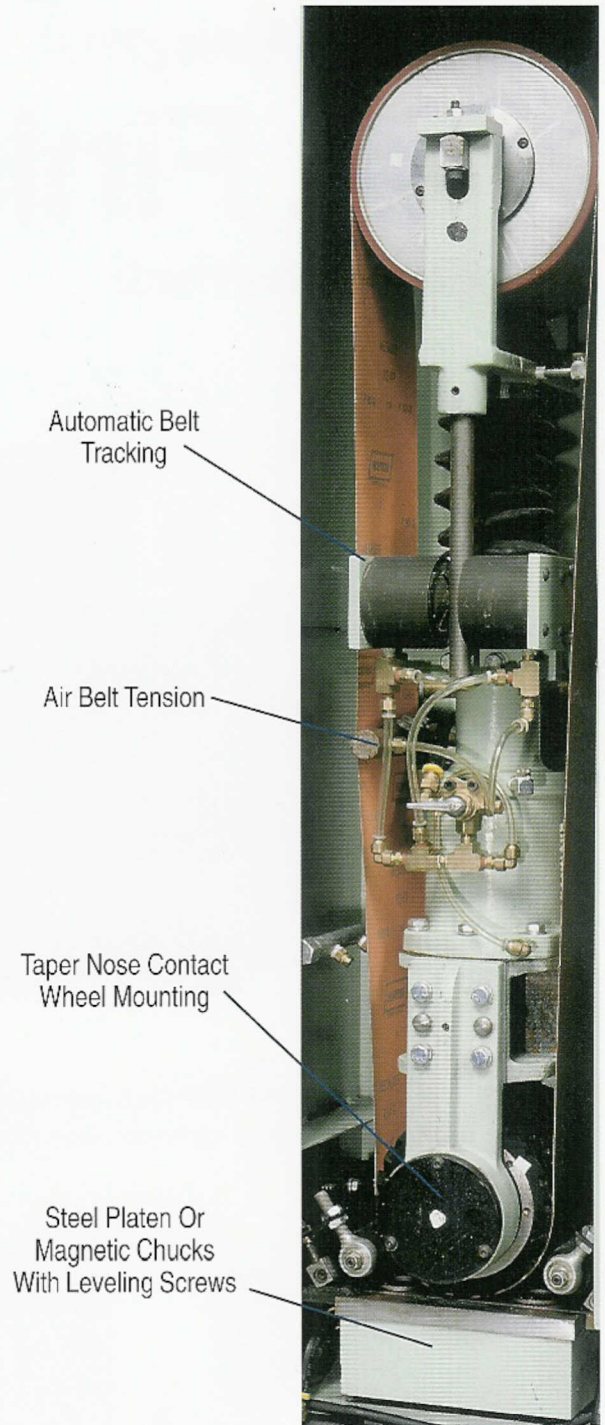

Send Samples For Free Evaluation

To have your parts evaluated free of charge in our testing laboratory, send one finished sample and a dozen or more rough samples along with your process requirements. Your samples will be returned with a machine recommendation.

Hammond Machinery
Inc

616 345-7151
1600 DOUGLAS KALAMAZOO • MI 49007
FAX 616 345-1710