

CE-400

Automatic Wastewater Treatment

Standard Features

- Fully Automatic Operation with Manual Overrides
- Maximum Throughput: 1200 gph
- 400-Gallon Treatment Tank
- Allen Bradley Micrologix PLC Controls
- U.L. Approved Control Panel
- 3 Horsepower Heavy Duty Agitator with Jet Basket
- Treatment Tank Auto Washdown
- Pre-Plumbed for Effluent Pump
- Automatic Chemical Feed System with 300 lb. Hopper, Complete with 2000 lb. Superbag Support Frame
- Double Rollers for Greater Dewatering
- **Equipment Measurements:** Length: 10'4", Width: 7'4", Height: 11'11", Weight: 5,000 lbs.

Optional Features

- 3.0 Cubic Yard Dumpster with False Bottom for Dewatering
- pH Control System for Treatment Tank
- Stainless Steel Construction
- 2" Cast Iron Influent Diaphragm Pump
- 2" Aluminum Effluent Diaphragm Pump
- Auto Washdown for Filtrate Tank
- Equalization and Reuse Tanks



(System shown with stainless steel option)

Ringwood's wastewater treatment units optimize the use of clay based flocculants to clarify industrial wastewaters.

Ringwood Environmental, Inc. Wastewater Products

6715 West 73rd Street • Bedford Park, IL 60638 • 708.458.6000 • FAX 708.458.1051

CE-400

Automatic Wastewater Treatment

NOTE: Items in **RED** are standard equipment that can be located on either side of the CE-400. Items in **BLUE** are optional equipment.

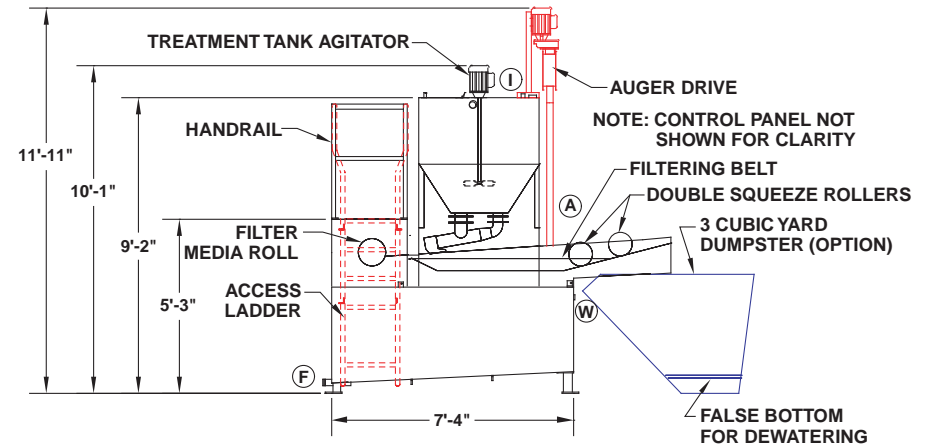
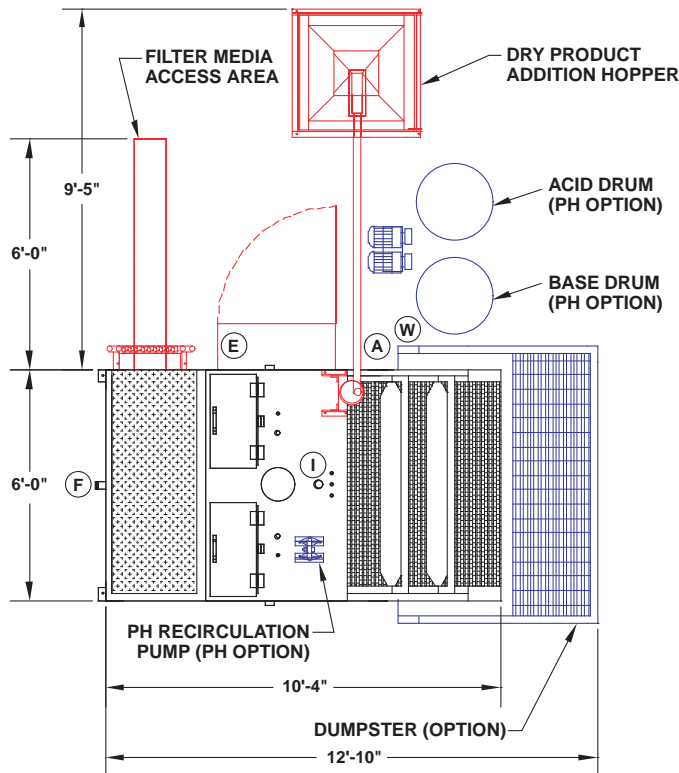

Service Requirements

- E** 480 VAC, 30 AMP, Grounded, 3 Phase Power Terminated at the Disconnect in the CE-400 Control Panel.
- A** 1" FNPT Air Supply Connection. 80-100 PSI, Clean, Dry, Air Required, With Locking Handle Valve on Service Line.
- W** 1" FNPT City Water Supply Connection. 30 PSI Required, With Locking Handle Valve on Service Line.
- I** 2" FNPT Influent Water Inlet Connection.
- F** 2" MNPT Effluent Water Discharge Connection.

Ringwood Environmental, Inc. Wastewater Products

6715 West 73rd Street • Bedford Park, IL 60638 • 708.458.6000 • FAX 708.458.1051